

10FUL-13A

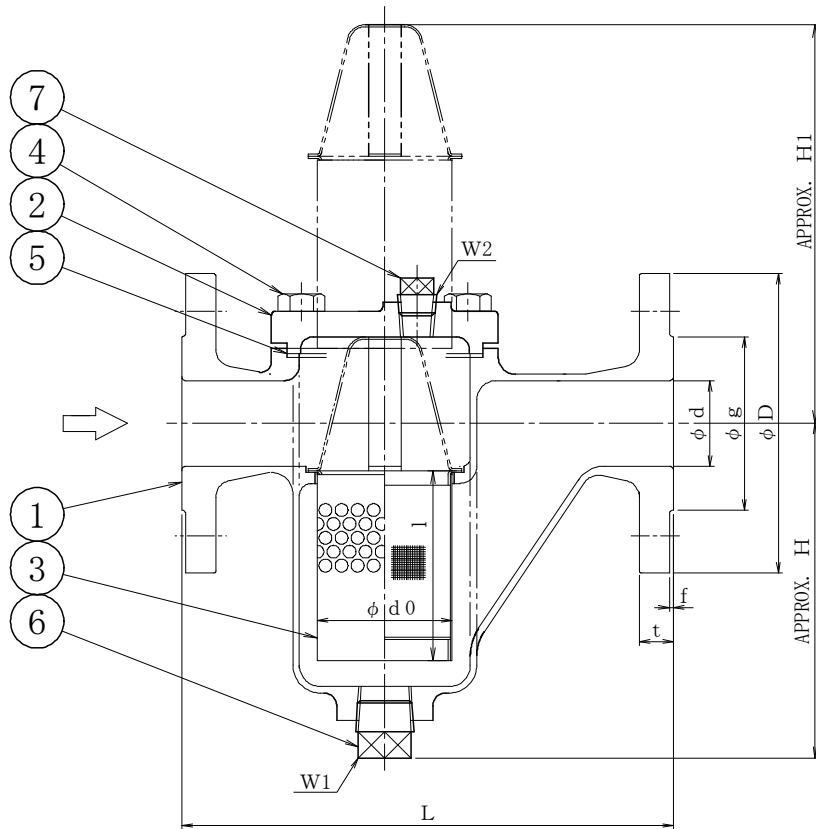

SIZE	d	L	FLANGED								d0	l	H	H1	W1	W2	Q'TY
			D	C	g	f	t	N	h								
15	1/2	20	156	95	70	51	1	12	4	15	33	70	112	135	R3/8	R3/8	
20	3/4	20	160	100	75	56	1	14	4	15	33	70	112	135	R3/8	R3/8	
25	1	25	180	125	90	67	1	14	4	19	43	80	130	156	R1/2	R3/8	
32	1 1/4	40	230	135	100	76	2	16	4	19	63	90	158	194	R3/4	R3/8	
40	1 1/2	40	230	140	105	81	2	16	4	19	63	90	158	194	R3/4	R3/8	
50	2	50	260	155	120	96	2	16	4	19	78	110	183	233	R3/4	R3/8	

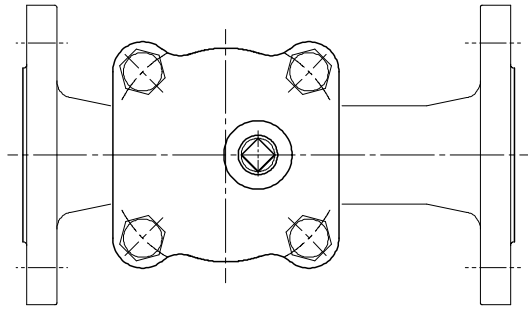
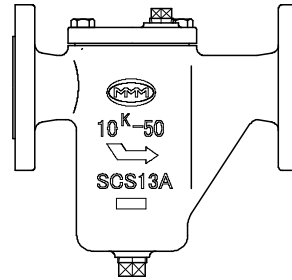

MARKING
EXAMPLE

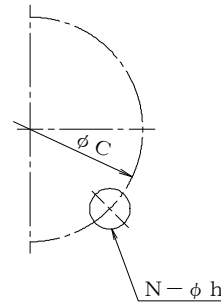

SCREEN

	MESH
	20 MESH
	40 MESH
	60 MESH
	80 MESH
	100 MESH

7	VENT PLUG	SUS304	1	
6	DRAIN PLUG	SUS304	1	
5	GASKET	T#9007-G20	1	
4	BOLT	SUS304	4	
3	SCREEN	SUS304	1	
2	COVER	SCS13A	1	
1	BODY	SCS13A	1	

No	NAME OF PART	MATERIAL	Q.T.Y	REMARKS
----	--------------	----------	-------	---------

NAME 10K
FLANGED U TYPE STRAINER

FLUID	DESIGN PRESSURE	DESIGN TEMPERATURE	TEST PRESSURE	BODY	
				(HYD)	(AIR)
	1.0 MPaG	150 °C		1.5 MPaG	— MPaG
				SEAT	
				(HYD)	(AIR)
				— MPaG	— MPaG
				(HYD)	(AIR)
				— MPaG	— MPaG

DRAWING No _____ MODEL No 10FUL-13A

DATE	A. P	C. K	D. S	D. W
FEB. 24. 2022	TAKAHASHI	TAKAHASHI	MORITA	HORIE

No	DESCRIPTION	DATE	A. P	C. K	D. W
REVISIONS					