

10SGL-13A

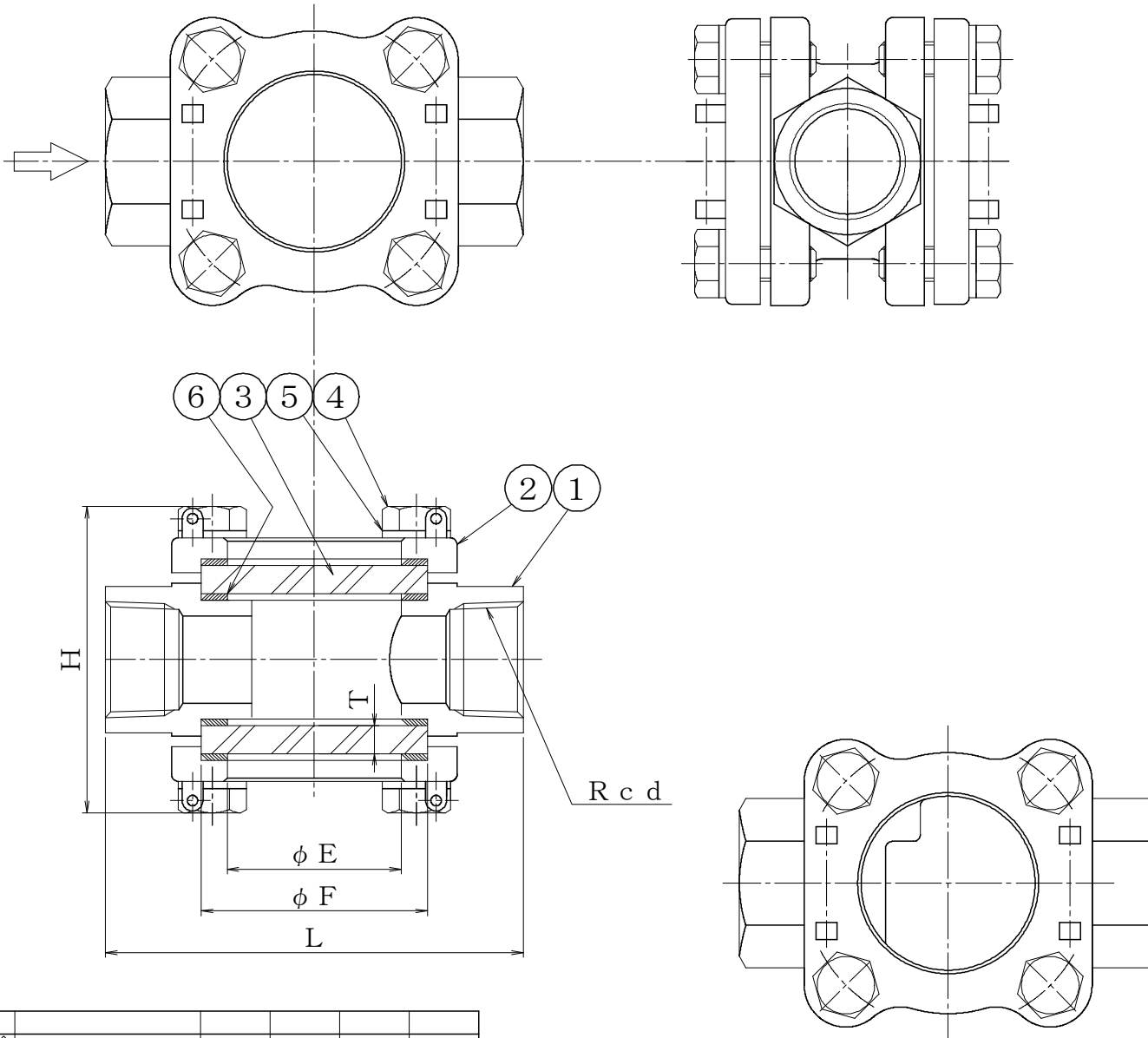

SIZE	d	L	H	E	F	T			
3/8	10	3/8	95	72	40	50	6		
1/2	15	1/2	95	72	40	50	6		
3/4	20	3/4	100	72	40	50	6		
1	25	1	120	88	50	65	8		
1 1/4	32	1 1/4	140	116	65	80	10		
1 1/2	40	1 1/2	145	116	65	80	10		
2	50	2	160	135	80	90	12		

No	NAME OF PART	MATERIAL	Q.T.Y	REMARKS
6	GASKET	T#9007-G20	4	
5	WASHER	SUS304	8	
4	BOLT	SUS304	8	
3	GLASS	TEMPERED GLASS	2	
2	COVER	SCS13A	2	
1	BODY	SCS13A	1	

NAME 10K CLEAR TYPE SCREWED SIGHT GLASS				
FLUID		TEST PRESSURE	BODY	(HYD) 1.5 MPaG (AIR) MPaG
DESIGN PRESSURE	1.0 MPaG		SEAT	(HYD) MPaG (AIR) MPaG
DESIGN TEMPERATURE	150 °C			(HYD) MPaG (AIR) MPaG
DRAWING No			MODEL No 10SGL-13A	
DATE	A. P	C. K	D. S	D. W
SEP. 25, 2014	MORITA	MORITA	MORITA	HORIE

No	DESCRIPTION	DATE	A. P	C. K	D. W
◇	SIZE	DEC. 8, 2020	TAKAHASI	TAKAHASI	MORITA
REVISIONS					

◇ 1 1/4 (3 2)