

SIZE	d	L	FLANGED								H	E	F	T	WEIGHT	
			D	C	g	f	t	N	h	kg					Q' ty	
10	3/8	15	130	90	65	46	1	12	4	15	72	40	50	6	2.6	
15	1/2	15	130	95	70	51	1	12	4	15	72	40	50	6	2.6	
20	3/4	20	130	100	75	56	1	14	4	15	72	40	50	6	3.0	
25	1	25	150	125	90	67	1	14	4	19	88	50	65	8	4.7	
32	1 1/4	32	170	135	100	76	2	16	4	19	116	65	80	10	6.0	
40	1 1/2	40	170	140	105	81	2	16	4	19	116	65	80	10	6.2	
50	2	50	200	155	120	96	2	16	4	19	135	80	95	12	8.0	

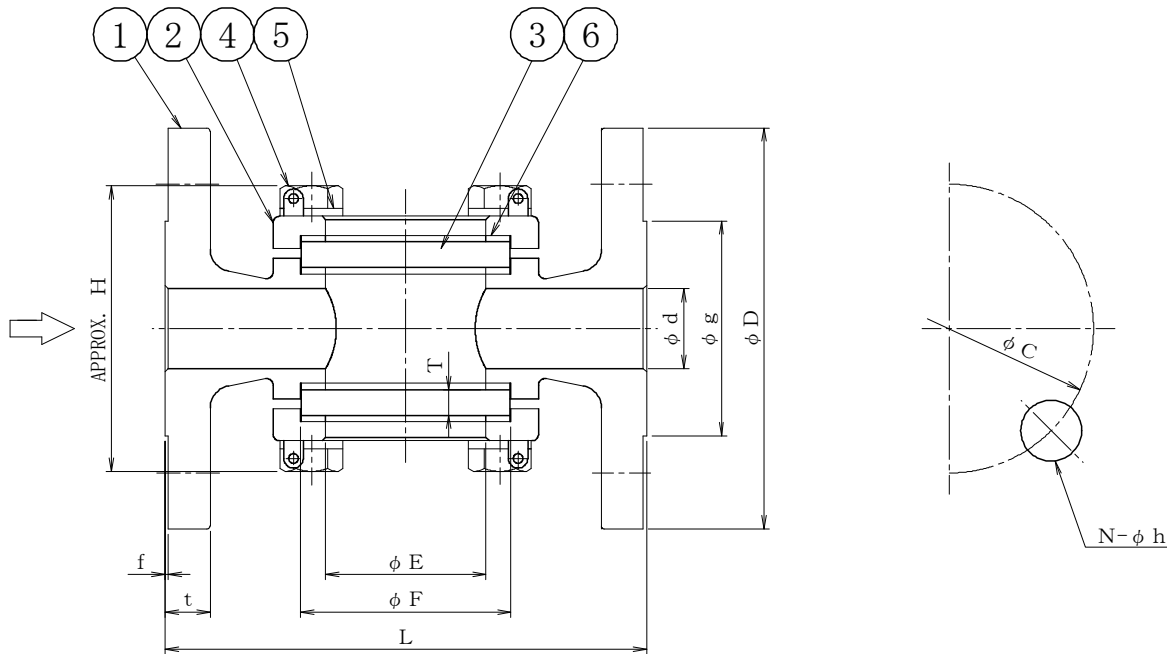

No	NAME OF PART	MATERIAL	Q.T.Y	REMARKS
6	GASKET	T#9007-G20	4	
5	WASHER	SUS304	8	
4	BOLT	SUS304	8	
3	GLASS	TEMPERED GLASS	2	
2	COVER	SCS13A	2	
1	BODY	SCS13A	1	

NAME 10K CLEAR TYPE  
FLANGED SIGHT GLASS

FLUID	DESIGN PRESSURE	DESIGN TEMPERATURE	TEST PRESSURE	BODY	SEAT
	1.0 MPaG	150 °C		(HYD) 1.5 MPaG (AIR) — MPaG	(HYD) — MPaG (AIR) — MPaG
				(HYD) — MPaG (AIR) — MPaG	(HYD) — MPaG (AIR) — MPaG

DRAWING No		MODEL No 10FGL-13A		
DATE	A. P	C. K	D. S	D. W
APR. 17. 2023	TAKAHASHI	TAKAHASHI	MORITA	HORIE

No	DESCRIPTION	DATE	A. P	C. K	D. W
REVISIONS					