

# 10GVF-BP-14-20A

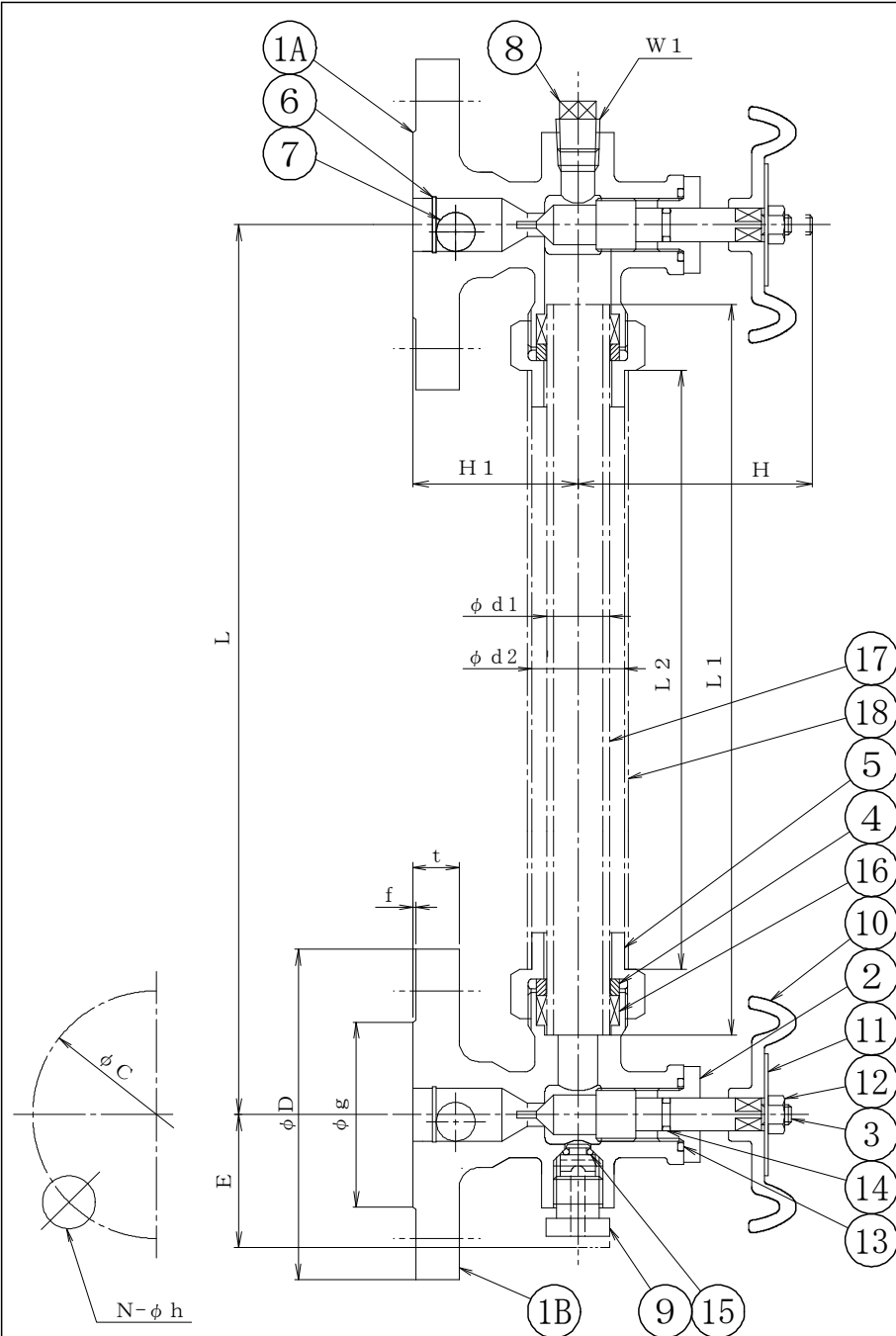

SIZE	3/4	FLANGED							H	H1	d1	d2	E	*1 L	*2 L1	*2 L2	W1	Q'TY
		D	C	g	f	t	N	h										
20	3/4	100	75	56	1	14	4	15	74	50	19	28	38	—	L-48	L-87	R1/4	

18	PROTECTOR	*3	—	1	
17	GAUGE TUBE	*3	—	1	
16	GLAND PACKING	EPDM	◇	2	
15	O RING	EPDM	◇	1	
14	O RING	EPDM	◇	2	
13	O RING	EPDM	◇	2	
12	WHEEL NUT	SUS304		2	
11	NAME PLATE	A1100P		2	
10	HAND WHEEL	ADC12		2	
9	DRAIN PLUG	SUS316		1	
8	PLUG	SUS316		1	
7	CHECK BALL	PTFE		2	
6	STOP RING	SUS316		2	
5	CAP NUT	SUS304		2	
4	GLAND BUSH	SUS316		2	
3	STEM	SUS316		2	
2	BONNET	SUS316		2	
1B	BODY	SCS14		1	
1A	BODY	SCS14		1	
No	NAME OF PART	MATERIAL	Q.TY	REMARKS	

## NOTE

- \* 1 L寸法はご指定寸法とさせていただきます。
- \* 2 L1, L2寸法はご指定ありましたL寸法から表の数値を引いた寸法とさせていただきます。
- \* 3 GAUGE TUBE, PROTECTORの材質はご指定どおりとさせていただきます。

NAME				
10K FLANGED				
TUBULAR LEVEL GAUGE				
FLUID		TEST PRESSURE	BODY	(HYD) 0.75 MPaG (AIR) MPaG
DESIGN PRESSURE	0.5 MPaG		SEAT	(HYD) MPaG (AIR) 0.6 MPaG
DESIGN TEMPERATURE	R.T °C			(HYD) MPaG (AIR) MPaG
DRAWING No			MODEL No 10GVF-BP-14	
DATE	A.P	C.K	D.S	D.W
OCT. 21. 2013	MORITA	MORITA	MORITA	HORIE

◇	Changed part no.	APR. 02. 2021	TAKAHASHI	TAKAHASHI	HORIE
◇	Changed material	JUN. 25. 2014	HISAKA	HISAKA	HORIE
No	DESCRIPTION	DATE	A.P	C.K	D.W
REVISIONS					