

10GVF-BB-14

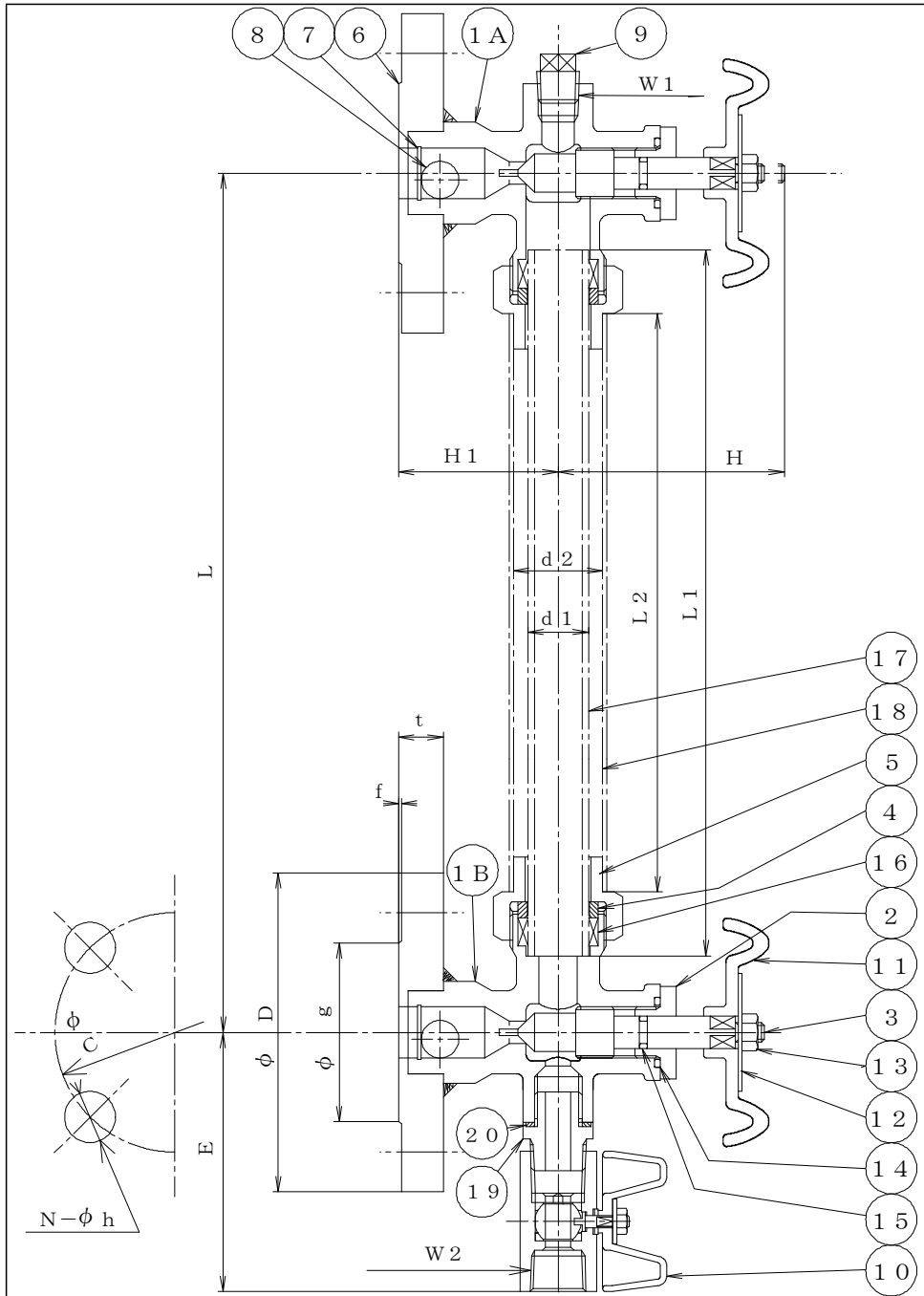

SIZE	FLANGED								H	H1	d1	d2	E	L1	L2	W1	W2
	D	C	g	f	t	N	h										
10	3/8	90	65	46	1	12	4	15	59	41	12	22	78	L-47	L-80	R1/4	Rc1/4
15	1/2	95	70	51	1	12	4	15	59	41	12	22	78	L-47	L-80	R1/4	Rc1/4
25	1	125	90	67	1	14	4	19	74	50	19	28	81	L-48	L-87	R1/4	Rc3/8

20	GASKET	V#7010	1	
19	JOINT	SUS316	1	
18	PROTECTOR	_____	1	
17	GAUGE TUBE	_____	1	
16	GLAND PACKING	EPDM	◇	2
15	O RING	EPDM	◇	2
14	O RING	EPDM	◇	2
13	WHEEL NUT	SUS304	2	
12	NAME PLATE	A1100P	2	
11	HAND WHEEL	ADC12	2	
10	DRAIN VALVE	SUS316	1	
9	PLUG	SUS316	1	
8	CHECK BALL	PTFE	2	
7	STOP RING	SUS316	2	
6	BODY FLANGE	SUS316	2	
5	CAP NUT	SUS304	2	
4	GLAND BUSH	SUS316	2	
3	STEM	SUS316	2	
2	BONNET	SUS316	2	
1B	BODY	SCS14	1	
1A	BODY	SCS14	1	
No	NAME OF PART	MATERIAL	Q.T.Y	REMARKS

NAME				
10K FLANGED				
TUBULAR LEVEL GAUGE				
FLUID		TEST PRESSURE	BODY	(HYD) 0.75 MPaG (AIR) MPaG
DESIGN PRESSURE	0.5 MPaG		SEAT	(HYD) MPaG (AIR) 0.6 MPaG
DESIGN TEMPERATURE	R.T °C			(HYD) MPaG (AIR) MPaG
DRAWING No		MODEL No 10GVF-BB-14		
DATE	A.P	C.K	D.S	D.W
APR. 2, 2011	MORITA	MORITA	MORITA	MORITA

NOTE

- * 1 L寸法はご指定寸法とさせていただきます。
- * 2 L1, L2寸法はご指定ありましたL寸法から表の数値を引いた寸法とさせていただきます。
- * 3 GAUGE TUBE, PROTECTORの材質はご指定どおりとさせていただきます。

No	DESCRIPTION	DATE	A.P	C.K	D.W
◇	Changed material	JUN. 25, '14	HISAKA	HISAKA	HORIE

REVISIONS