

# SF-H-13

SIZE	d	H	I	S	B	X	◇ H1	◇ H2	◇ E	◇ F	WEIGHT Kg	
1 1/2	40	1 1/2	160	22	60	140	160	96	64	85	7	2.5
2	50	2	170	26	72	140	160	106	64	85	7	2.5
2 1/2	65	2 1/2	202	30	88	158	175	131	71	99	7	3.5
3	80	3	225	35	100	168	200	148	77	107	7	4.5
4	100	4	280	40	135	232	240	182	98	110	7	11.0

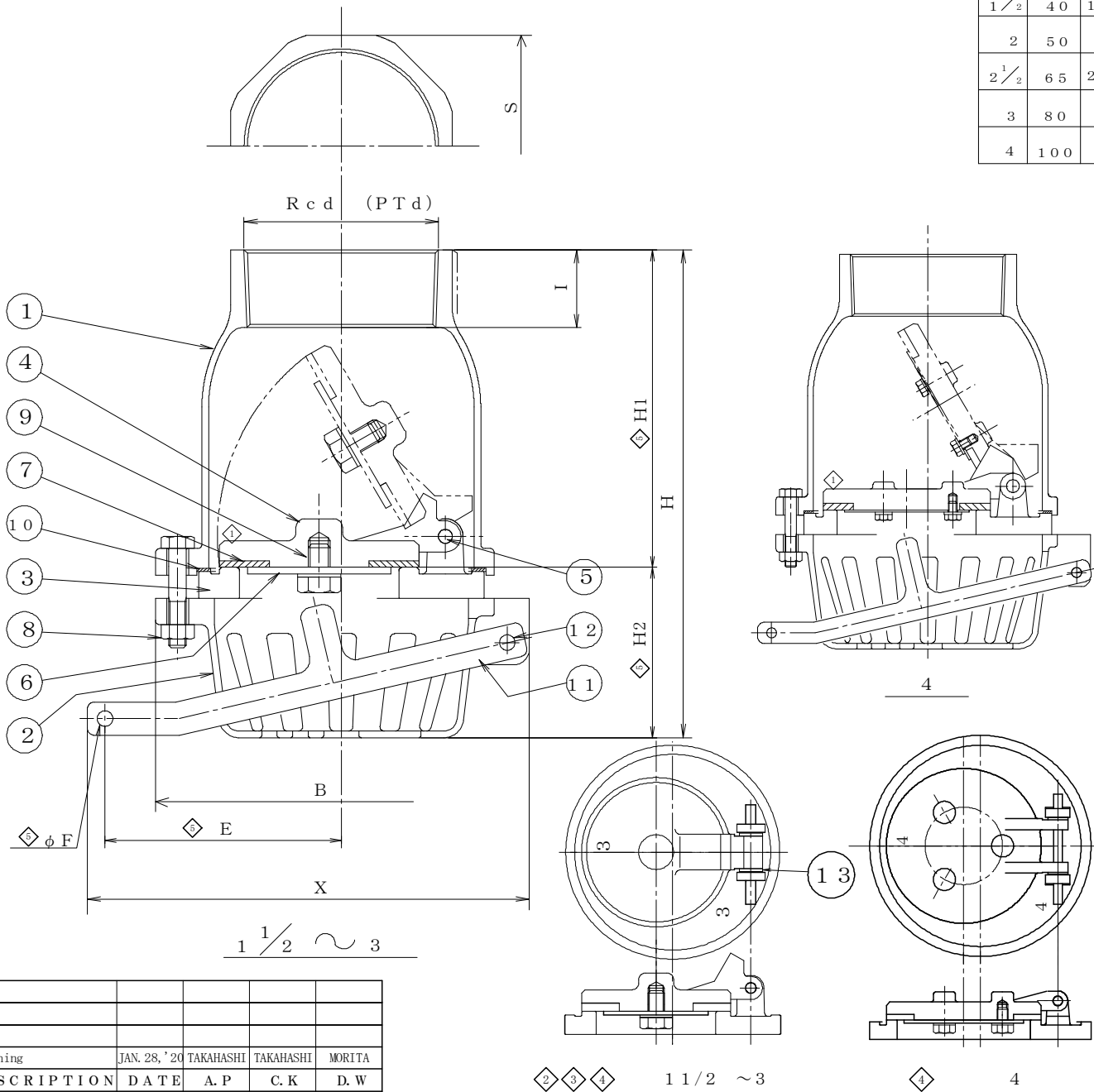

13	WASHER	SUS304	2	◇ 2 ◇ 3 ◇ 4
12	BOLT NUT	SUS304	1	
11	LEVER	SCS13	1	
10	GASKET	V#7010	1	
9	BOLT WASHER	SUS304	SET	
8	BOLT NUT	SUS304	SET	
7	SEAT PACKING	Si	1	
6	DISC PLATE	SUS304	1	
5	PIN	SUS303	1	
4	DISC	SCS13	1	
3	SEAT	SCS13	1	
2	STRAINER	SCS13	1	
1	BODY	SCS13	1	
No	NAME OF PART	MATERIAL	Q.T.Y	REMARKS

NAME				
SCREWED FOOT VALVE				
FLUID		TEST PRESSURE	BODY	(HYD) 0.2 MPaG (AIR) MPaG
DESIGN PRESSURE	MPaG		SEAT	FILLING WATER TEST
DESIGN TEMPERATURE	60~80 °C			(HYD) MPaG (AIR) MPaG
DRAWING No			MODEL No SF-H-13	
DATE	A. P	C. K	D. S	D. W
SEP. 9. 2005	MORITA	MORITA	MORITA	MORITA

No	DESCRIPTION	DATE	A. P	C. K	D. W
◇ 5	Dimensioning	JAN. 28, '20	TAKAHASHI	TAKAHASHI	MORITA
REVISIONS					