

SFM-13

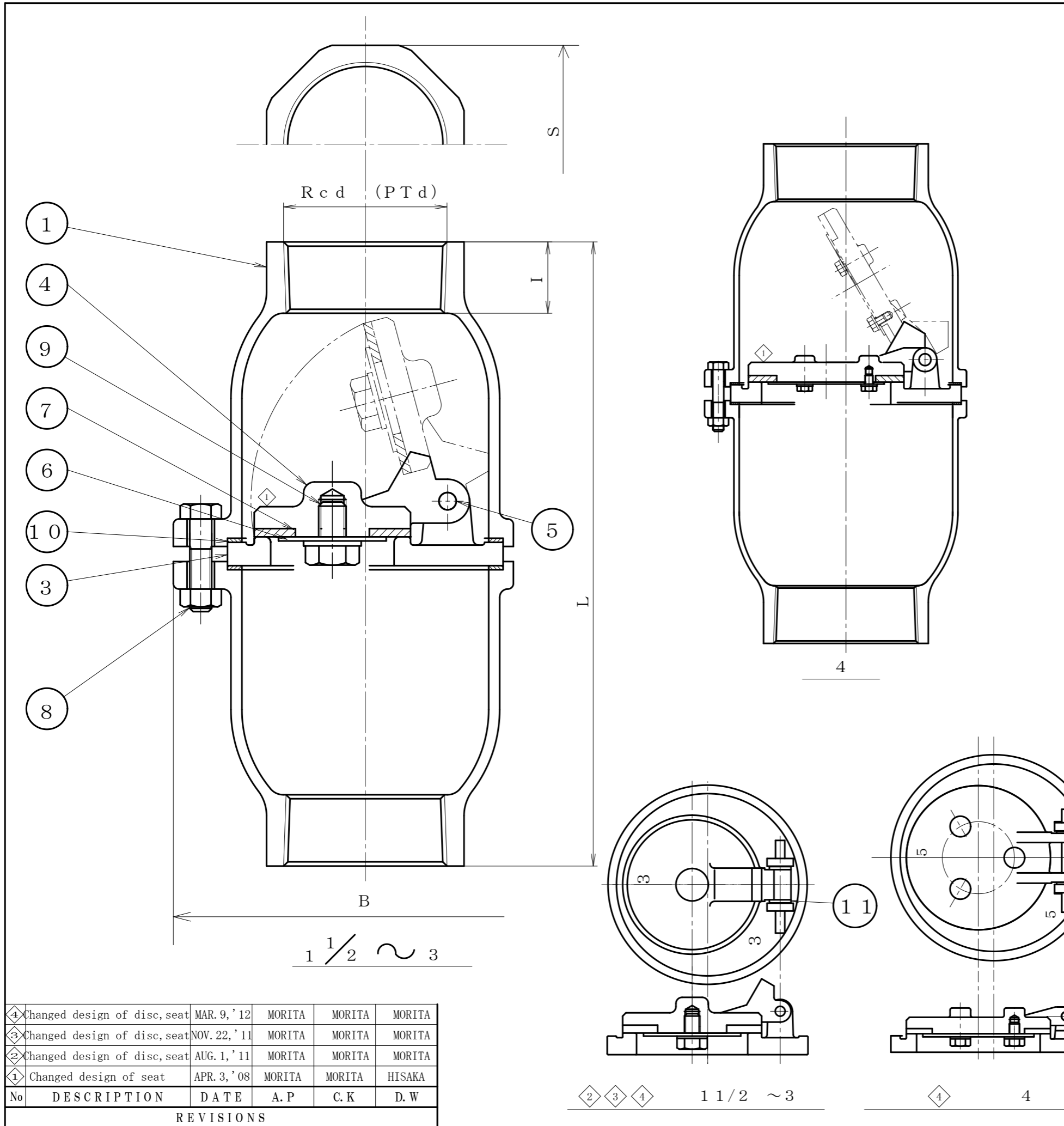

SIZE	d	L	I	S	B					
1 1/2	40	1 1/2	202	22	60	140				
2	50	2	229	26	72	140				
2 1/2	65	2 1/2	270	30	88	158				
3	80	3	303	35	100	168				
4	100	4	374	40	135	232				

No	NAME OF PART	MATERIAL	Q.T.Y	REMARKS
11	WASHER	SUS304	2	②③④
10	GASKET	T#1995	2	
9	BOLT WASHER	SUS304	SET	
8	BOLT NUT	SUS304	SET	
7	SEAT PACKING	CR	1	
6	DISC PLATE	SUS304	1	
5	PIN	SUS304	1	
4	DISC	SCS13	1	
3	SEAT	SCS13	1	
2				
1	BODY	SCS13	2	

NAME					SCREWED				
INTERMEDIATE FOOT VALVE									
FLUID			BODY	(HYD)	0.2	MPaG			
				(AIR)		MPaG			
DESIGN PRESSURE		MPaG	TEST PRESSURE	SEAT	FILLING WATER TEST				
DESIGN TEMPERATURE		R. T °C			(HYD)	MPaG			
					(AIR)	MPaG			
DRAWING No					MODEL No SFM-13				
DATE	A. P	C. K	D. S	D. W					
SEP. 9. 2005	MORITA	MORITA	MORITA	MORITA					

No	DESCRIPTION	DATE	A. P	C. K	D. W
④	Changed design of disc, seat	MAR. 9, '12	MORITA	MORITA	MORITA
③	Changed design of disc, seat	NOV. 22, '11	MORITA	MORITA	MORITA
②	Changed design of disc, seat	AUG. 1, '11	MORITA	MORITA	MORITA
①	Changed design of seat	APR. 3, '08	MORITA	MORITA	HISAKA

REVISIONS