

# 10FFM-13

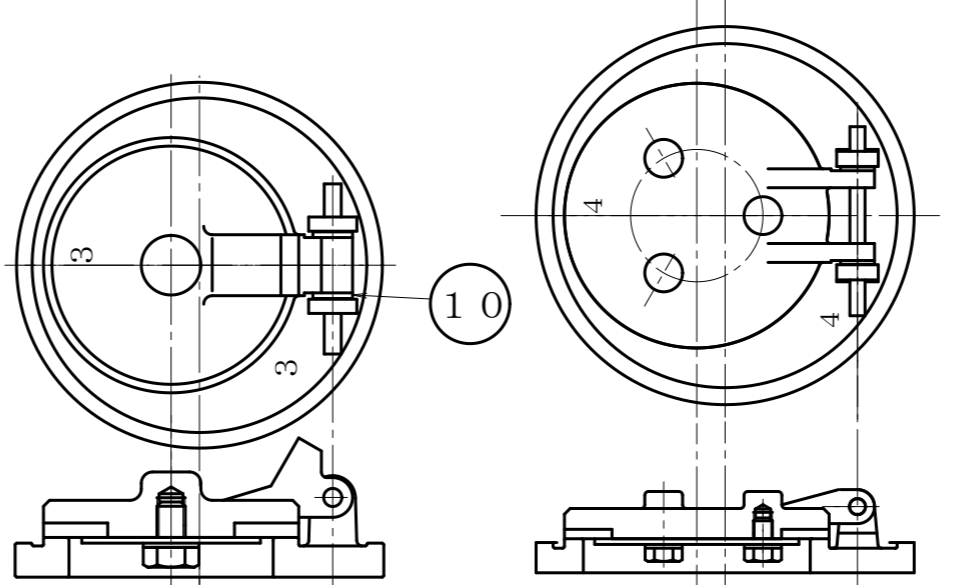
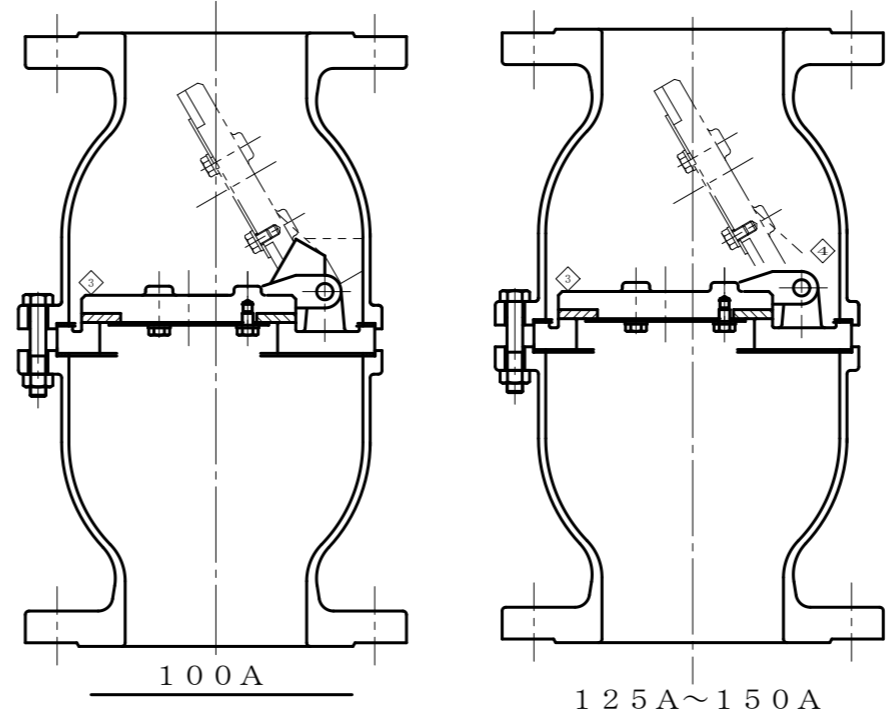
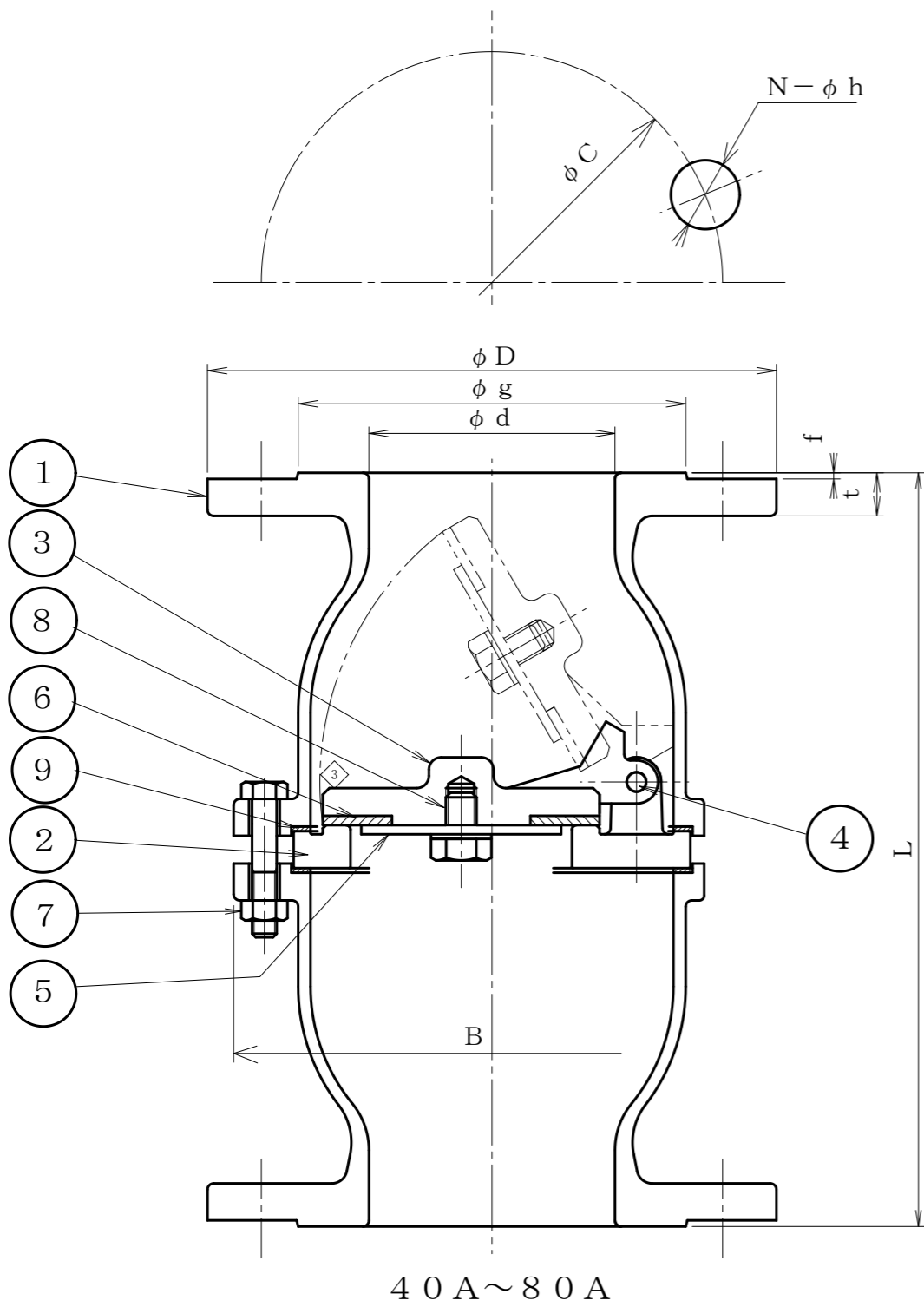

SIZE	d	FLANGED								B	
		L	D	C	g	f	t	N	h		
40	1 1/2	40	189	140	105	81	2	14	4	19	140
50	2	50	189	155	120	96	2	14	4	19	140
65	2 1/2	65	220	175	140	116	2	14	4	19	158
80	3	80	250	185	150	126	2	14	8	19	168
100	4	100	338	210	175	151	2	16	8	19	232
125	5	125	365	250	210	182	2	18	8	23	255
150	6	150	432	280	240	212	2	18	8	23	278

No	DESCRIPTION	DATE	A. P	C. K	D. W
8	Changed dimension	JUN. 21, '18	MORITA	MORITA	MORITA
7	Changed design of disc, seat	MAR. 9, '12	MORITA	MORITA	MORITA
6	Changed design of disc, seat	OCT. 26, '11	MORITA	MORITA	MORITA
5	Changed design of disc, seat	JUL. 28, '11	MORITA	MORITA	MORITA
4	Changed design of disc	JUN. 18, '09	MORITA	MORITA	MORITA
3	Changed design of seat	APR. 3, '08	MORITA	MORITA	HISAKA
2	Changed dimension	MAR. 5, '08	MORITA	MORITA	HISAKA
1	Changed dimension	JUL. 24, '06	MORITA	MORITA	MORITA

REVISIONS

No	NAME OF PART	MATERIAL	Q.T.Y	REMARKS
10	WASHER	SUS304	2	5 6 7
9	GASKET	T#1995	2	
8	BOLT WASHER	SUS304	SET	
7	BOLT NUT	SUS304	SET	
6	SEAT PACKING	CR	1	
5	DISC PLATE	SUS304	1	
4	PIN	SUS303	1	
3	DISC	SCS13	1	
2	SEAT	SCS13	1	
1	BODY	SCS13	2	

NAME 10 K				
FLANGED FOOT VALVE				
FLUID		TEST PRESSURE	BODY	(HYD) 0.2 MPaG (AIR) MPaG
DESIGN PRESSURE	MPaG		SEAT	FILLING WATER TEST
DESIGN TEMPERATURE	R. T °C			(HYD) MPaG (AIR) MPaG
DRAWING No			MODEL No 10FFM-13	
DATE	A. P	C. K	D. S	D. W
SEP. 24, 2005	MORITA	MORITA	MORITA	MORITA

5 6 7 40A~80A

6 7 100A~150A