

10FF-H-13

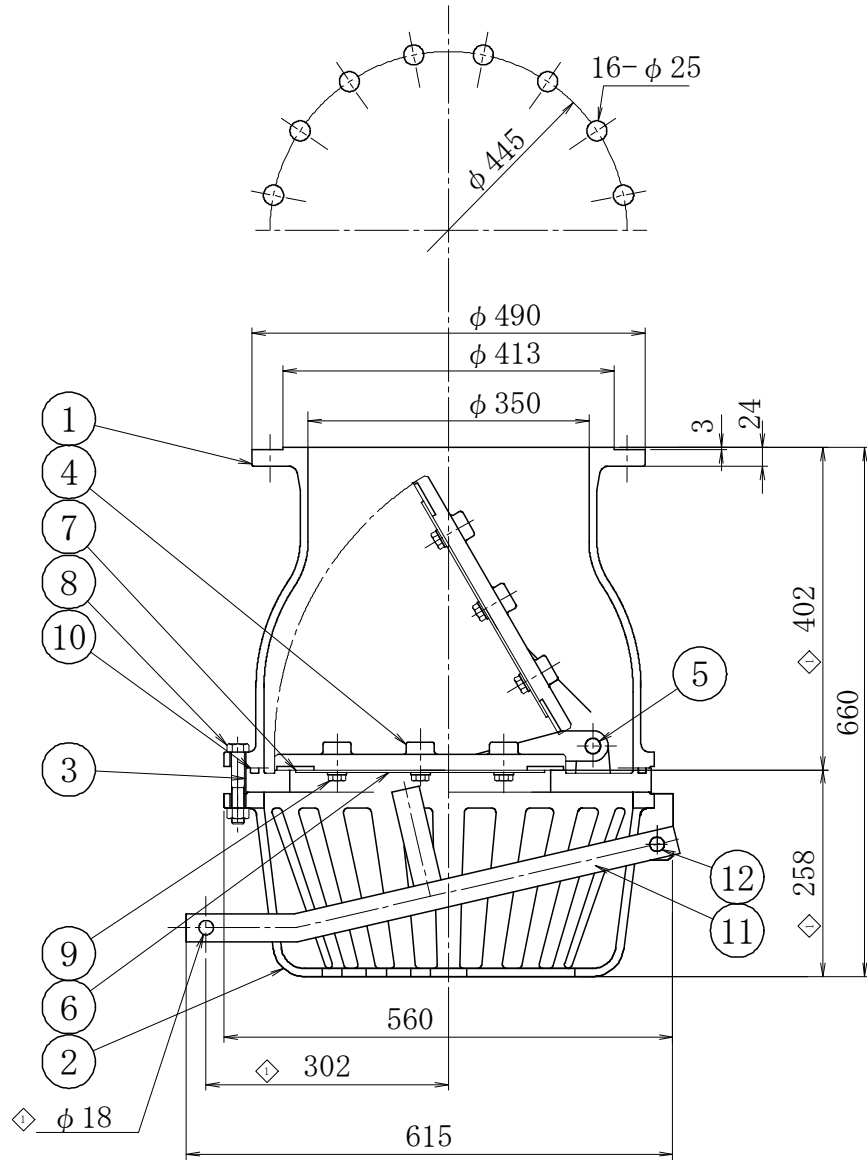

12	BOLT NUT	SUS304	1SET	
11	LEVER	SUS304	1	
10	RING	Si	1	
9	BOLT WASHER	SUS304	SET	
8	BOLT NUT	SUS304	SET	
7	SEAT PACKING	Si	1	
6	DISC PLATE	SUS304	1	
5	PIN	SUS304	1	
4	DISC	SCS 13	1	
3	SEAT	SCS 13	1	
2	STRAINER	SCS 13	1	
1	BODY	SCS 13	1	
No	NAME OF PART	MATERIAL	Q.T.Y	REMARKS

NAME 10K-350

FLANGED FOOT VALVE

FLUID		TEST PRESSURE	BODY	(HYD)	0.2 MPaG
				(AIR)	MPaG
DESIGN PRESSURE	MPaG	TEST PRESSURE	SEAT	FILLING WATER TEST	
DESIGN TEMPERATURE	60~80 °C			(HYD)	MPaG
				(AIR)	MPaG

DRAWING No

MODEL No 10FF-H-13

DATE	A. P	C. K	D. S	D. W
SEP. 16, 2005	MORITA	MORITA	MORITA	MORITA

No	DESCRIPTION	DATE	A. P	C. K	D. W
3					
2					
1	Dimensioning	JAN. 28, '20	TAKAHASHI	TAKAHASHI	MORITA
REVISIONS					



THREE-M INDUSTRY CO., LTD.